

Substituent Effects on the Ring-Opening Mechanism of Lithium Bromocyclopropylidenoids to Allenes

Akin Azizoglu,^{*,†,§} Metin Balci,[‡] Jean-Luc Miesusset,[§] and Udo H. Brinker[§]

Department of Chemistry, University of Balikesir, TR-10145, Balikesir, Turkey, Department of Chemistry, Middle East Technical University, TR-06531, Ankara, Turkey, and Chair of Physical Organic and Structural Chemistry, Faculty of Chemistry, University of Vienna, Währinger Str. 38, A-1090 Vienna, Austria

azizoglu@balikesir.edu.tr

Received May 22, 2008

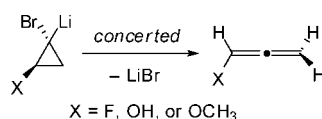

The ring-opening reactions of lithium bromocyclopropylidenoids to allenes have been investigated computationally at the B3LYP/6-31G(d) level of theory. Formally, two pathways can be considered: the reaction may either proceed in a concerted fashion or stepwise with the intermediacy of a free cyclopropylidene. In both cases, the loss of the bromide ion determines the kinetic of the reaction. The stability of the reactive intermediate, i.e., the carbene, is dependent on the substituent. Cyclopropylidenes bearing an electron-donating group (+M) are extremely unstable and ring-open readily to the allene. In contrast, bromocyclopropylidenoids with electron-withdrawing groups are particularly stable species. Here, a high energy barrier needs to be overcome in order to split off bromide and to generate the corresponding carbene or allene. Still, for most of the monosubstituted cyclopropylidenes investigated during this study, the activation energy for the cyclopropylidene to allene rearrangement is lower than the energy required for parent compound (X = H) except for X = -SiH₃ and -CF₃.

Introduction

For the past decades, the synthesis of allenes has attracted increasing interest because it allows chemists to access a variety of structurally interesting and biologically active products.^{1,2} From among the numerous synthetic approaches to allenes currently available, the conversion of 1,1-dihalocyclopropanes

in general, and the dibromo derivatives in particular,³ to the corresponding allenes upon treatment with alkyllithium reagents has played an important role (Figure 1).⁴ The mechanism of Doering–Moore–Skattebøl rearrangement was gradually uncovered and proved to involve a carbene-like intermediate, called a lithium carbenoid (**2**), formed through bromine–lithium exchange.^{5,6} The instability and reactivity of lithium carbenoids makes them difficult to study by conventional experimental methods, although low-temperature ¹³C NMR spectroscopy was used for structure determination of a few of the more stable bromoalkyllithium carbenoids which supports the notion of a loosened C–Br bond.⁷ Hence, carbenoids generated by the

* Corresponding author. Phone: +90 266 6121000/1116. Fax: +90 266 6121215.

[†] University of Balikesir.

[‡] Middle East Technical University.

[§] University of Vienna.

(1) (a) Brummond, K. M.; DeForrest, J. E. *Synthesis* **2007**, 795–813. (b) Ma, S. M. *Chem. Rev.* **2005**, *105*, 2829–2871. (c) Christl, M. In *Modern Allene Chemistry*; Krause, N., Ed.; Wiley-VCH: Weinheim, Germany, 2005; Vol. 1, pp 242–357. (d) Hoffmann-Röder, A.; Krause, N. *Angew. Chem., Int. Ed.* **2004**, *43*, 1196–1216. (e) Balci, M.; Taskesenligil, Y. In *Advances in Strained and Interesting Organic Molecules*; Halton, B., Ed.; JAI Press Inc: Stamford, CT, 2000; Vol. 8, pp 43–81.

(2) (a) Li, C. Y.; Zhu, B. H.; Ye, L. W.; Jing, Q.; Sun, X. L.; Tang, Y.; Shen, Q. *Tetrahedron* **2007**, *63*, 8046–8053. (b) Azizoglu, A.; Demirkol, O.; Kilic, T.; Yildiz, Y. K. *Tetrahedron* **2007**, *63*, 2409–2413. (c) Wang, J.; Sheridan, R. S. *Org. Lett.* **2007**, *9*, 3177–3180. (d) Altable, M.; Filippone, S.; Martin-Domech, A.; Guell, M.; Sola, M.; Martin, N. *Org. Lett.* **2006**, *8*, 5959–5962. (e) Kilbas, B.; Azizoglu, A.; Balci, M. *Helv. Chim. Acta* **2006**, *89*, 1449–1456. (f) Janßen, C. E.; Krause, N. *Eur. J. Org. Chem.* **2005**, 2322–2329. (g) Algi, F.; Özen, R.; Balci, M. *Tetrahedron Lett.* **2002**, *43*, 3129–3131.

(3) (a) Sydnes, L. K. *Chem. Rev.* **2003**, *103*, 1133–1150. (b) Fedorynski, M. *Chem. Rev.* **2003**, *103*, 1099–1132.

(4) (a) Doering, W. v. E.; LaFlamme, P. M. *Tetrahedron* **1958**, *2*, 75–79. (b) Moore, W. R.; Ward, H. R. J. *Org. Chem.* **1960**, *25*, 2073. (c) Skattebøl, L. *Tetrahedron Lett.* **1961**, *5*, 167–172.

(5) Siegel, H. *Top. Curr. Chem.* **1982**, *106*, 55–78.

(6) Backes, J.; Brinker, U. H. In *Houben-Weyl (Methoden der Organischen Chemie)*; Regitz, M., Ed.; Thieme: Stuttgart, Germany, 1989; Vol. E 19b, pp 391–510.

(7) (a) Seebach, D.; Siegel, H.; Müllen, K.; Hiltbrunner, K. *Angew. Chem., Int. Ed. Engl.* **1979**, *18*, 784–789. (b) Seebach, D.; Siegel, H.; Gabriel, J.; Hässig, R. *Helv. Chim. Acta* **1980**, *63*, 2046–2053.

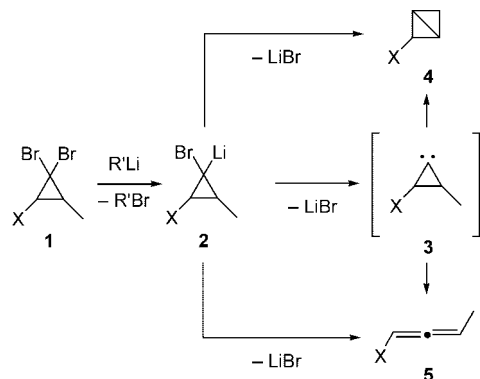

FIGURE 1. General representation of the transformation of *gem*-dibromocyclopropanes into bicyclo[1.1.0]butanes and allenes.

organometallic route largely correspond with those of free cyclopropylidenes in their intramolecular reactions.^{6,8,9}

Occasionally, the formation of allenes (**5**) from *gem*-dibromocyclopropanes (**1**) competes with the formation of intramolecular CH-insertion products, usually bicyclobutanes (**4**), obtained in quantities ranging from traces to exclusive products.^{10–14} The result of this competition is usually determined by the nature of substituents,^{15–17} conformational change in the skeleton,^{18,19} and electronic effects.²⁰ Bicyclobutanes are obtained when allene formation is difficult, for example, with bicyclo[4.1.0]heptan-7-ylidene affording **7** and **8**,^{21,22} with tetrasubstituted cyclopropylidenes due to steric crowding,^{13,15,23} or with polycyclic cyclopropylidenes in order to avoid the generation of a bridgehead allene.^{24,25} However, it is interesting to note that the Doering–Moore–Skattebøl route *does* succeed for the methoxy derivative **9** of 7,7-dibromobicyclo[4.1.0]heptane. Compound **11**, presumably formed via dimerization of 1-methoxycyclohepta-1,2-diene (**10**), was isolated in 85% yield (Scheme 1).²⁶

To date, little is known about the detailed reaction mechanisms of carbenoids, and several research groups have turned

SCHEME 1. Treatment of 7,7-Dibromobicyclo[4.1.0]heptane and Its Methoxy Derivative with MeLi

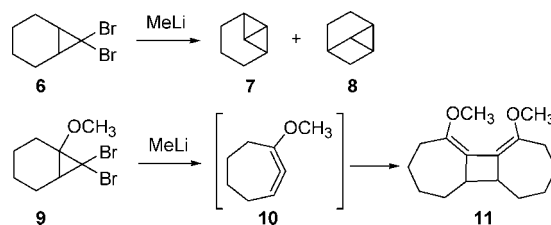

to computational studies to investigate the structure^{27,28} and reactions of these species in more detail.^{29,30} Although the rearrangement of free cyclopropylidenes (**3**) has been the subject of thorough theoretical investigations, which conclude that the reaction is generally characterized by a low activation energy,^{22,31–33} there are only limited computational studies in the literature on the ring opening of carbenoids to allenes.^{25,34} Moreover, the substituent effects on the rearrangement of carbenoid (**2**) or free carbene (**3**) have not been explored computationally before.

Herein, we would like to report full details of a computational study on the ring opening of both carbenoids and free carbenes to the corresponding allenes and the influence of substituents on these rearrangements.

Computational Details

The Gaussian 03 program³⁵ was used for density functional theory calculations, employing Becke's³⁶ three-hybrid method and the exchange functional of Lee, Yang, and Parr (B3LYP).³⁷ The geometry optimizations of all the structures were achieved at B3LYP/6-31G(d), which is very successful in modeling and predicting the energy for the isomerization energy of carbenes to allenes.^{26,10,22,25,38} Some calculations were repeated with full geometry optimizations at higher levels; B3LYP/6-311++G(d,p) and MP2/6-31+G(d,p). Stationary points were characterized as minima or transition structures by way of an analytic evaluation of harmonic frequencies at the level of geometry optimization. The intrinsic reaction coordinates (IRC)³⁹ were also followed to verify the energy profiles connecting each transition state to the correct local minima, by using the second-order Gonzalez–Schlegel method.^{40a,b} All energies reported here include unscaled zero-point vibrational energies. Molecule structures were visualized by using the GaussView program.^{40c} Carbenes were considered as singlet

(8) Kirmse, W. In *Carbene Chemistry*, 2nd ed.; Academic Press: New York, 1971; p 462.

(9) Jones, W. M.; Brinker, U. H. In *Pericyclic Reactions*; Marchand, A. P., Lehr R. E., Eds.; Academic Press: New York, 1977; p 169.

(10) Azizoglu, A.; Ozen, R.; Hokelek, T.; Balci, M. *J. Org. Chem.* **2004**, *69*, 1202–1206.

(11) Creary, X.; Jiang, Z.; Butchko, M.; McLean, K. *Tetrahedron Lett.* **1996**, *37*, 579–582.

(12) Jelinek-Fink, H.; Christl, M.; Peters, E.-M.; Peters, K.; von Schnering, H. G. *Chem. Ber.* **1991**, *124*, 2569–2575.

(13) Moore, W. R.; Taylor, K. G.; Müller, P.; Hall, S. S.; Gaibel, Z. L. F. *Tetrahedron Lett.* **1970**, *11*, 2365–2368.

(14) Moore, W. R.; Hill, J. B. *Tetrahedron Lett.* **1970**, *11*, 4343–4346.

(15) Moore, W. R.; Hill, J. B. *Tetrahedron Lett.* **1970**, *11*, 4553–4556.

(16) Baird, M. S. *J. Chem. Soc., Chem. Commun.* **1979**, 776–777.

(17) Taylor, K. G. *Tetrahedron* **1982**, *38*, 2751–2772.

(18) Taylor, K. G.; Chaney, J. *J. Am. Chem. Soc.* **1976**, *98*, 4158–4163.

(19) Taylor, K. G.; Chaney, J.; Deck, J. *J. Am. Chem. Soc.* **1976**, *98*, 4163–4167.

(20) Baird, M. S. *J. Chem. Soc., Chem. Commun.* **1971**, 1145–1146.

(21) (a) Moore, W. R.; Ward, H. R.; Merritt, R. F. *J. Am. Chem. Soc.* **1961**, *83*, 2019. (b) Köbrich, W.; Goyert, W. *Tetrahedron* **1968**, *24*, 4327–4342.

(22) Bettinger, H. F.; Schleyer, P. v. R.; Schreiner, P. R.; Schaefer, H. F. *J. Org. Chem.* **1997**, *62*, 9267–9275.

(23) (a) Skattebøl, L. *Acta Chem. Scand.* **1963**, *17*, 1683. (b) Skattebøl, L. *Tetrahedron Lett.* **1970**, *11*, 2361–2364. (c) Brown, D. W.; Hendrick, M. E.; Jones, M., Jr. *Tetrahedron Lett.* **1973**, *14*, 3951–3954.

(24) (a) Paquette, L. A.; Chamot, E.; Browne, A. R. *J. Am. Chem. Soc.* **1980**, *102*, 637–643. (b) Nakazaki, M.; Yamamoto, K.; Maeda, M.; Sato, O.; Tsutsui, T. *J. Org. Chem.* **1982**, *47*, 1435–1438. (c) Warner, P. M.; Chang, S.-C.; Koszewski, N. J. *Tetrahedron Lett.* **1985**, *26*, 5371–5374.

(25) Miesusset, J.-L.; Brinker, U. H. *J. Org. Chem.* **2005**, *70*, 10572–10575.

(26) Taylor, K. G.; Hobbs, W. E.; Clark, M. S.; Chaney, J. *J. Org. Chem.* **1972**, *37*, 2436–2443.

(27) (a) Pratt, L. M.; Merry, S.; Nguyen, S. C.; Quan, P.; Thanh, B. T. *Tetrahedron* **2006**, *62*, 10821–10828. (b) Pratt, L. M.; Ramachandran, B.; Xidos, J. D.; Cramer, C. J.; Truhlar, D. G. *J. Org. Chem.* **2002**, *37*, 7607–7612.

(28) Luke, B. T.; Pople, J. A.; Schleyer, P. V.; Clark, T. *Chem. Phys. Lett.* **1983**, *102*, 148–154.

(29) Ando, K. *J. Org. Chem.* **2006**, *71*, 1837–1850.

(30) Hermann, H.; Lohrenz, J. C. W.; Kühn, A.; Boche, G. *Tetrahedron* **2000**, *56*, 4109–4115.

(31) Bettinger, H. F.; Schreiner, P. R.; Schleyer, P. v. R.; Schaefer, H. F. *J. Phys. Chem.* **1996**, *100*, 16147–16154.

(32) (a) Valtazanos, P.; Elbert, S. T.; Ruedenberg, K. *J. Am. Chem. Soc.* **1986**, *108*, 3147–3149. (b) Valtazanos, P.; Elbert, S. T.; Xantheas, S.; Ruedenberg, K. *Theor. Chim. Acta* **1991**, *78*, 287–326. (c) Valtazanos, P.; Ruedenberg, K. *Theor. Chim. Acta* **1991**, *78*, 397–416.

(33) (a) Kakkai, R. *Int. J. Quantum Chem.* **2003**, *94*, 93–104. (b) Kakkai, R.; Garg, R.; Chadha, P. *THEOCHEM* **2002**, *617*, 141–147.

(34) Wang, B.; Deng, C.; Xu, L.; Tao, F. *Chem. Phys. Lett.* **1989**, *161*, 388–392.

(35) Frisch, M. J. et al. *Gaussian 03*, revision C.2; Gaussian, Inc.: Wallingford, CT, 2004. Full reference given in the Supporting Information.

(36) Becke, A. D. *J. Chem. Phys.* **1993**, *98*, 5648–5652.

(37) Lee, C.; Yang, W.; Parr, R. G. *Phys. Rev. B* **1988**, *37*, 785–789.

(38) Miesusset, J.-L.; Brinker, U. H. *Eur. J. Org. Chem.* **2008**, 3363–3368.

(39) (a) Fukui, K. *J. Phys. Chem.* **1970**, *74*, 4161–4162. (b) Fukui, K. *Acc. Chem. Res.* **1981**, *14*, 363–368. (c) Some of the IRC plots are available in the Supporting Information.

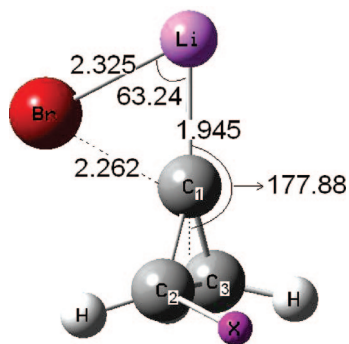

FIGURE 2. Structure of the cyclopropylidene·LiBr carbenoid **12a** (X = H); bond lengths (Å) and bond angles (deg).

because this represents the ground-state of cyclopropylidenes.^{40d,e} The calculations were performed on the most stable conformer of each substituted 1-bromo-1-lithiocyclopropane. Wiberg bond orders (WBO)⁴¹ and natural atomic charges were also calculated within the natural bond orbital (NBO)⁴² analysis at the B3LYP/6-31G(d) level.

Results and Discussion

Structure of 1-Bromo-1-lithiocyclopropane 12. The lithium–bromine exchange reaction of 1,1-dibromocyclopropane with methyllithium affords 1-bromo-1-lithiocyclopropane, of which the molecular structure was analyzed. We calculated the structure of carbenoid **12** in which case only one minimum structure was found, whereas LiCH₂F has three²⁸ and H₂C=CLiF has two.⁴³ The data also show that Li as well as Br are positioned on one side of the cyclopropane ring plane, and the C–Br bond is bridged by lithium, and all ligands of the carbene center are located in a cone (Figure 2). The structure of carbenoid **12** corresponds to a distorted-tetrahedron coordination. In all carbenoids investigated in this study, the bromine is antiperiplanar to substituent X because it corresponds to the most stable arrangement.

In Table 1, the most significant structural data of carbenoids **12a–m** (X = –H, –CN, –CF₃, –Br, –Cl, –CH₂OH, –CH₃, –SiH₃, –F, –Ph, –OH, –OCH₃, and –NH₂) are summarized. A positive value of (%) means an elongation, a negative value of (%) describes a shortening with regard to the reference bond. As seen from Table 1, the C(1)–Li bonds are in the range of 1.938–1.947 Å. This corresponds to minimal changes in the structure of carbenoids **12a–12m** if compared with the C–Li bond length (1.980 Å) in H₃C–Li. However, C(1)–Br bond elongations are in the range of 9.77% (minimum for X = –CN, **12c**) and 16.0% (maximum for X = –SiH₃, **12b**) as compared to the bond in H₃C–Br (1.965 Å). This means that the most strongly elongated bond in **12a–m** is C(1)–Br. Concerning the Li–Br distances in the carbenoids, the elongations, as compared to the bond length in the Li–Br salt (2.167 Å), are between 7.20% and 9.97%. Hence, the C(1)–Br bond is the weakest and the C(1)–Li bond is the strongest one in the LiCBr ring

when compared to the elongation and shortening values of the bonds reported in Table 1, except for **12c**. Moreover, the effect of substituents studied is more pronounced for the C(1)–Br bond than for the other bonds.

Alternatively, chemical bond disruption and formation can be quantified by the Wiberg bond order (WBO), which reflects the superposition of electron density between two interacting atoms.⁴¹ A large WBO indicates a strong covalent bonding interaction between the two relevant atoms. Table 1 also shows the Wiberg bond orders of several bonds of **12a–m** calculated by using NBO analysis. The results depict that C(1)–Li bond has an ionic rather than covalent nature because the estimated Wiberg bond orders for the C(1)–Li are quite small (in the range of 0.097 and 0.124). This conclusion is supported by the substantial positive charge centered on lithium in the range of +0.88 and +0.90. Furthermore, the C(1)–Br bond of **12b** (X = –SiH₃) has the weakest covalent bonding interactions within C(1)–Br bonds of carbenoids studied due to its smallest bond order value, 0.756. On the contrary, the C(1)–Br bond of **12c** (X = –CN) has a WBO of 0.861, which is the highest one, so it has the strongest covalent bonding interactions.

The thermodynamics of the dissociation of carbenoids to produce a free carbene depends on the state of aggregation.⁴⁴ For example, the “decomposition temperature” of the organometallic species in THF is higher than in diethyl ether.⁴⁵ Solvent molecules may be strongly coordinated. The number of coordinated solvent molecules in the monomer and dimer shows significant temperature dependence, as does the aggregation state of the alkylolithiums.⁴⁶

The calculated dimerization energy ($\Delta E = E_{\text{dimer}} - 2E_{\text{monomer}}$) of LiBr is indeed substantial, –52.3 kcal/mol at B3LYP/6-31G(d) (Figure 3). It is almost equal to the dimerization energy of LiCl, –52.5 kcal/mol from ab initio calculations at the MP4SDQ/6-311+G(d)//MP2/6-31G(d) level.⁴⁷ Aggregation of LiBr serves as a driving force for the desired reaction because it facilitates the elimination of LiBr from the carbenoid **12** and it reduces the reactivity of LiBr toward the generated free carbene, i.e., in order to give **14**. Thus, it removes LiBr from the reaction mixture, thereby increasing the chances that the free carbene may be formed (the dimer of LiBr is expected to be less reactive than the monomer).

In this study upon the reactivity of 1-bromo-1-lithiocyclopropanes, only the two extreme cases will be considered: Calculations of the free cyclopropylidenes can help to describe the chemistry of the carbene, whereas the results obtained from the computations on bromocyclopropyl lithiums can give insight into the maximal effect of the lingering lithium and bromide ions upon the carbene reactivity.

Stepwise Ring-Opening of 1-Bromo-1-lithiocyclopropane 12. The elimination of LiBr from carbenoid **12** starts readily with the transition state **TS1** (**12** → **13**), where the C–Br bond breaking occurs. Since coordination of the lithium ion and solvation are not considered, relatively low absolute energy values are obtained. Then, **12** rearranges to the carbene–lithium complex **13**, where the positively charged Li is coordinated to the lone pair of the carbene (Scheme 2). In particular, the natural

(40) (a) Gonzalez, C.; Schlegel, H. B. *J. Phys. Chem.* **1990**, *94*, 5523–5527. (b) Gonzalez, C.; Schlegel, H. B. *J. Chem. Phys.* **1991**, *95*, 5853–5860. (c) GaussView, Version 3.09, Dennington, R., II.; Keith, T.; Millam, J.; Eppinnett, K.; Hovell, W. L.; Gilliland, R. Semichem, Inc.: Shawnee Mission, KS, 2003. (d) Cramer, C. J.; Worthington, S. E. *J. Phys. Chem.* **1995**, *99*, 1462–1465. (e) Kakkar, R.; Padhi, B. S. *Int. J. Quantum Chem.* **1996**, *58*, 389–398.

(41) Wiberg, K. B. *Tetrahedron* **1968**, *24*, 1083–1096.

(42) (a) Reed, A. E.; Curtiss, L. A.; Weinhold, F. *Chem. Rev.* **1988**, *88*, 899–926. (b) Reed, A. E.; Schleyer, P. v. R. *J. Am. Chem. Soc.* **1990**, *112*, 1434–1445.

(43) Wang, B.; Deng, C. *Chem. Phys. Lett.* **1988**, *147*, 99–104.

(44) Rohde, C.; Clark, T.; Kaufmann, E.; Schleyer, P. v. R. *J. Chem. Soc., Chem. Commun.* **1982**, 882–884.

(45) (a) Köbrich, G. *Angew. Chem., Int. Ed. Engl.* **1972**, *11*, 473–485. (b) Nefedov, O. M.; Dyachenko, A. I. *Angew. Chem., Int. Ed. Engl.* **1972**, *11*, 507–508.

(46) Pratt, L. M.; Truhlar, D. G.; Cramer, C. J.; Kass, S. R.; Thompson, J. D.; Xidos, J. D. *J. Org. Chem.* **2007**, *72*, 2962–2966.

TABLE 1. Calculated Bond Lengths d (Å), Bond Elongations (%), and Wiberg Bond Orders (WBO) in Carbenoids **12a–m** As Compared to Bond Lengths of $\text{H}_3\text{C–Br}$, Li–Br , and $\text{H}_3\text{C–Li}$, Respectively, at the B3LYP/6-31G(d) Level of Theory

X	C(1)–Br			Li–Br			C(1)–Li			
	d (Å)	elong ^a (%)	WBO	d (Å)	elong ^b (%)	WBO	d (Å)	elong ^c (%)	WBO	
a	–H	2.262	15.1	0.769	2.325	7.29	0.105	1.945	–1.77	0.119
b	–SiH ₃	2.279	16.0	0.756	2.323	7.20	0.105	1.950	–1.52	0.109
c	–CN	2.157	9.77	0.861	2.383	9.97	0.086	1.947	–1.67	0.098
d	–CF ₃	2.167	10.3	0.849	2.372	9.46	0.088	1.941	–1.97	0.099
e	–Br	2.173	10.6	0.824	2.376	9.64	0.087	1.939	–2.07	0.097
f	–Cl	2.171	10.5	0.831	2.370	9.37	0.089	1.945	–1.77	0.103
g	–CH ₂ OH	2.229	13.4	0.796	2.329	7.48	0.101	1.945	–1.77	0.117
h	–CH ₃	2.251	14.6	0.776	2.326	7.34	0.102	1.944	–1.82	0.118
i	–F	2.161	9.97	0.834	2.369	9.32	0.088	1.941	–1.97	0.107
j	–Ph	2.226	13.3	0.796	2.343	8.12	0.098	1.944	–1.82	0.110
k	–OH	2.182	11.0	0.814	2.338	7.89	0.095	1.954	–1.31	0.119
l	–OCH ₃	2.185	11.2	0.821	2.361	8.95	0.092	1.938	–2.12	0.109
m	–NH ₂	2.238	13.9	0.771	2.330	7.52	0.100	1.944	–1.82	0.124

^a $\text{H}_3\text{C–Br}$ distance: 1.965 Å. ^b Li–Br distance: 2.167 Å. ^c $\text{H}_3\text{C–Li}$ distance: 1.980 Å.

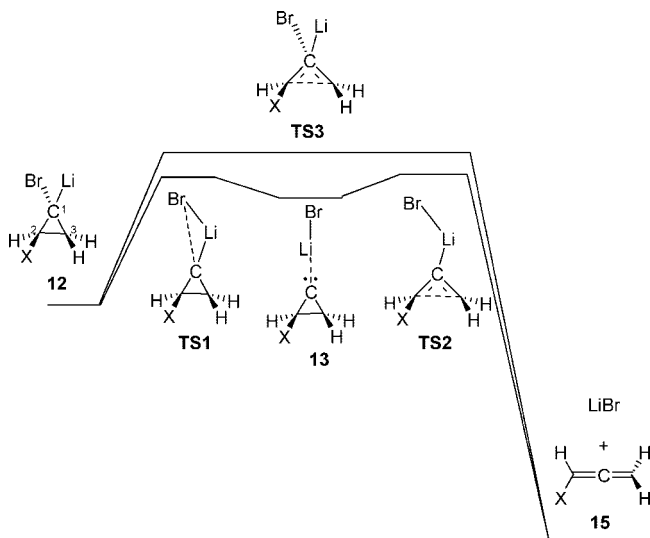

$$E_{\text{monomer}} = -2579.31227 \quad E_{\text{dimer}} = -5158.70789$$

FIGURE 3. Optimized structures of monomer and dimer of LiBr and their energies (E , in au) including zero-point energy energies at the B3LYP/6-31G(d) level.**SCHEME 2.** Mechanisms of the Ring Opening of Carbenoid **12** to Allene **15**

atomic charges on the carbenic carbon C(1) for the structures of **12a**, **TS1a**, and **13a** are -0.458 , $+0.039$, and $+0.063$, respectively. It can easily be understood that the release of a bromide anion from carbenoid **12** results in the change of its character from a nucleophile to an electrophile. The NBO analysis confirms this depiction of the release of lithium bromide. Here, carbenoid **12a** is presented as a compound consisting of two units, a $\text{C}_3\text{H}_4\text{Br}$ moiety with a formal charge of -0.888 and a lithium ion. In this description of structure **12a**, the C–Br bond is strongly populated with occupancy of 1.981 electrons. The interactions between the two units are principally due to electron donation from the lone pair on the carbon atom assisted by electron donation from the bromine. In contrast, structure **13a** and **TS1a** (**12a** \rightarrow **13a**) are already described as an association of a C_3H_4 moiety with LiBr. In

TABLE 2. Calculated Energy Barriers (kcal/mol) for the Concerted and Stepwise Isomerizations of Carbenoids **12a–m** to Allenes **15a–m** at the B3LYP/6-31G(d), B3LYP/6-311++G(d,p) (in Parentheses) and MP2/6-31+G(d,p) (Underlined) Levels of Theory

X	concerted		stepwise		
	TS3 ^a	TS1 ^a	13 ^a	TS2 ^a	
a	–H	–/(–)/–	7.6/(7.4)/14.0	6.3/(7.3)/12.9	8.6/(9.1)/13.9
b	–SiH ₃	–/(–)/–	5.6/(5.1)/11.9	4.0/(4.9)/11.2	8.7/(9.4)/15.3
c	–CN	18.7	17.6	17.3	19.1
d	–CF ₃	17.8	15.1	14.5	16.9
e	–Br	12.9	13.4	12.2	12.9
f	–Cl	12.7/(11.4)/17.0	14.7/(–)/–	–/(–)/–	–/(–)/–
g	–CH ₂ OH	9.9	8.8	7.0	7.5
h	–CH ₃	8.9/(7.6)/13.1	7.9/(7.5)/15.8	6.3/(7.2)/14.4	6.7/(10.6)/14.4
i	–F	8.6/(8.9)/14.3	–/(–)/–	–/(–)/–	–/(–)/–
j	–Ph	8.4/(7.4)	8.5/(8.3)	6.6/(8.0)	6.4/(7.8)
k	–OH	5.7/(5.0)/10.9	–/(–)/–	–/(–)/–	–/(–)/–
l	–OCH ₃	5.6/(4.7)/10.8	–/(–)/–	–/(–)/–	–/(–)/–
m	–NH ₂	3.8/(2.8)/7.6	–/(–)/–	–/(–)/–	–/(–)/–

^a Energies in kcal/mol relative to **12a–m**, respectively.

13a, the cyclopropylidene unit is slightly positively charged ($+0.029$ e) since electron donation to lithium still occurs as revealed by a second-order perturbation theory analysis of the Fock matrix. Finally, the difference of the energies of HOMO and LUMO can sometimes serve as a measure of the excitability and the reactivity of the molecule studied. For the structure of **12a**, **TS1a**, and **13a**, the energy gaps between HOMO and LUMO are 0.169, 0.067, and 0.051 eV, respectively. Hence, they are getting narrower when carbenoid **12** isomerizes to structure **13**.

The activation energy barrier for the isomerization of carbenoid **12a** to **13a**, the cleavage of the C–Br bond, is found to be 7.6 kcal/mol (**TS1a**). Correspondingly, the barrier for the back-reaction of **13a** with a barrier of only 1.3 kcal/mol is very low. Hence, in this reversible process, substituents attached to the cyclopropylidene ring should affect the formation of **13**. In a second step, the three-membered ring collapses to allene **15** by overcoming a very low energy barrier (**TS2** (**13** \rightarrow **15**)) except for X = $-\text{SiH}_3$ (Table 2). We have investigated the influence of substituents on these activation energy barriers. As one can see from Table 2, the carbenoids attached to electron-withdrawing groups ($-\text{CN}$, $-\text{CF}_3$) have higher activation barriers than those attached to electron-releasing groups ($-\text{CH}_3$, $-\text{SiH}_3$, etc.). It is interesting to note that some results from carbenoids bearing $-\text{F}$, $-\text{Cl}$, $-\text{OH}$, $-\text{OCH}_3$, $-\text{NH}_2$ substituents are missing.

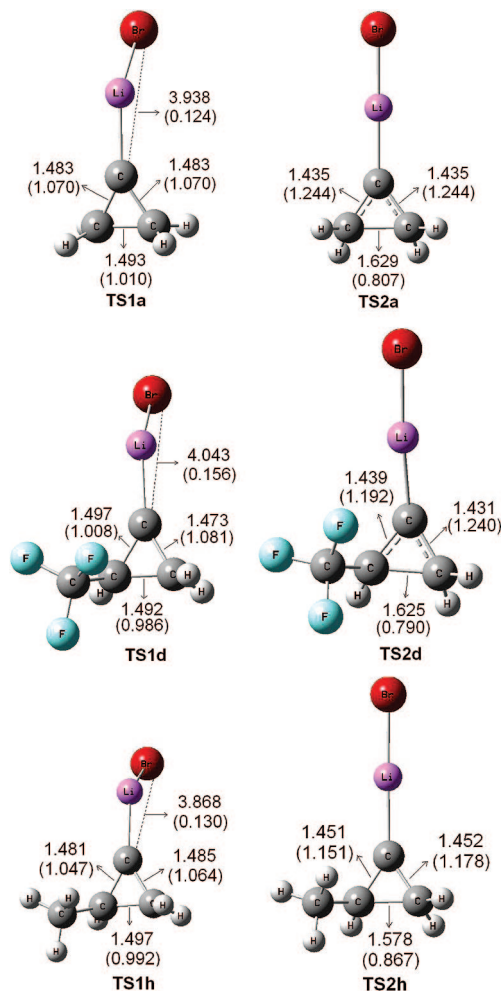

FIGURE 4. Optimized structures of **TS1d**, **TS1h**, **TS1j**, **TS2d**, **TS2h**, and **TS2j** with selected bond distances (Å) and bond orders (in parentheses) at the B3LYP/6-31G(d) level.

Indeed, the attempts to locate a minimum for structures **13f**, **13i**, **13k**, **13l**, and **13m** at the levels of B3LYP/6-31G(d), B3LYP/6-311++G(d,p), and MP2/6-31+G(d,p) lead directly to the corresponding allenes. For these substituents, the formation of allene **15** from 1-bromo-1-lithiocyclopropane **12** can only be computed as a concerted process (**TS3**). To indicate that no suitable geometry and energy results were obtained for these carbenoids, dashes (–) have been placed into Table 2.

Starting from **TS2s**, the ring openings of **13a–m** were followed by IRC analysis. For unsubstituted **13** (X = H), the IRC calculation^{39c} depicts that both methylene groups rotate in a disrotatory manner in the initial phase of the ring opening, maintaining C_s symmetry. However, one methylene group reverses its sense of rotation relative to the other, destroying C_s symmetry after passing **TS2a** (at $\phi \approx 95^\circ$). The overall motion then becomes conrotatory, until the relative orientation of the methylene groups is similar to the structure of allene. These results agree with those found for the ring-opening of cyclopropylidene to allene.^{31,32} On the other hand, IRC calculations^{39c} for substituted **13s** reveal that the ring opening starts with a nonsynchronous disrotatory motion of the methylene and CH(X) groups. The methylene group rotates faster than the CH(X) group until the transition structure (**TS2**) is reached. However, the CH(X) group reverses its sense of rotation relative to the methylene group after passing **TS2**. The overall motion

is now conrotatory. This is maintained until the methylene and CH(X) groups achieve the allene orientation. These results agree with those found for the ring-opening of *cis*- and *trans*-2,3-dimethylcyclopropylidene²² except that in these carbenoids the initial disrotatory motion of both methylene groups is synchronous, keeping either C_s symmetry (*cis* conformer) or C_2 symmetry (*trans* conformer). However, we were unable to obtain IRC calculations for the stepwise ring-opening of **12f**, **12i**, **12k**, **12l**, and **12m** to the corresponding allenes.

As carbenoid **12a–m** is activated to transition states **TS1a–m** and **TS2a–m**, considerable structural change occurs. The geometries of **TS1s** and **TS2s** for X = –H, –CF₃, and –CH₃ are given in Figure 4. In **TS1s**, the C(1)–Br bond distances increase to 3.938, 4.043, and 3.868 Å from their values of 2.262, 2.167, and 2.251 Å in **12a**, **12d**, and **12h**, respectively, whereas the C(2)–C(3) bond distances decrease to 1.493, 1.492, and 1.497 Å from their values of 1.503, 1.505, and 1.505 Å in **12a**, **12d**, and **12h**, respectively. As can be seen in Figure 4, the bond distances of **TS1s** do not fluctuate significantly with the nature of substituents. However, the variation in the bond distances of **TS2s** is in a larger domain. In particular, the C(2)–C(3) bond distances for **TS2a**, **TS2b**, **TS2c**, and **TS2d** are 1.629, 1.663, 1.655, and 1.625, respectively, whereas that for **TS2g**, **TS2h**, and **TS2j** they are 1.571, 1.578, 1.562, respectively.

Compared with the bond lengths, the Wiberg bond order (WBO) is a more balanced measure of the extent of a bond-formation or bond-breaking process along the reaction pathway. This theoretical tool is quite common in the computational study of reaction mechanisms.⁵⁰ The WBO values of **TS1s** and **TS2s** computed by NBO method for X = –H, –CF₃, and –CH₃ are given in Figure 4 (in parentheses). From the results of **TS1s**, it can be deduced that the C(1)–Br breaking bond occurs and the carbon–carbon bonds in the cyclopropane moiety get stronger. Moreover, the WBO values of the C(2)–C(3) bond for **TS2a**, **TS2d**, and **TS2h** are 0.807, 0.790, and 0.867, respectively, which indicate the breaking of the σ -bond between C(2) and C(3). On the contrary, WBO values of C(1)–C(2) and C(1)–C(3) bonds for **TS2a**, **TS2d**, and **TS2h** are 1.244–1.244, 1.192–1.240, and 1.151–1.178, respectively, which depict the formation of π -bonds.

Dissociation of the nonsolvated carbene–lithium complexes **13a–m** to the free carbenes **14a–m** and LiBr requires a high energy of approximately ~30 kcal/mol as calculated for compounds **12a–m**. The backward reaction, i.e., the complexation of LiBr to free carbene **14**, occurs without a barrier. However, the actual energy barriers of dissociation and complexation should depend on the solvent used and the state of aggregation in which organolithium compounds may exist. Different aggregates may exhibit different properties and reactivities.

Concerted Ring-Opening of 1-Bromo-1-lithiocyclopropane 12. Another point needing to be discussed is that the

(47) Hoffmann, D.; Dorigo, A.; Schleyer, P. v. R.; Reif, H.; Stalke, D.; Sheldrick, G. M.; Weiss, E.; Geissler, M. *Inorg. Chem.* **1995**, *34*, 262–269.

(48) (a) Jones, W. M.; Walbrick, J. M. *J. Org. Chem.* **1969**, *34*, 2217. (b) Jones, W. M.; Krause, D. L. *J. Am. Chem. Soc.* **1971**, *93*, 551.

(49) Olivella, S.; Lopez, N. *Chem.–Eur. J.* **2001**, *7*, 3951–3960.

(50) (a) Domingo, L. R.; Chamorro, E.; Perez, P. *J. Org. Chem.* **2008**, *73*, 4615–4624. (b) Alajarin, M.; Cabrera, J.; Pastor, A.; Sanchez-Andrada, P.; Bautista, D. *J. Org. Chem.* **2008**, *73*, 963–973. (c) Gomez-Bengoia, E.; Helm, M.; Plant, A.; Harrity, J. P. A. *J. Am. Chem. Soc.* **2007**, *129*, 2691–2699. (d) Notario, R.; Quijano, J.; Sanchez, C.; Velez, E. *J. Phys. Org. Chem.* **2005**, *18*, 134–141.

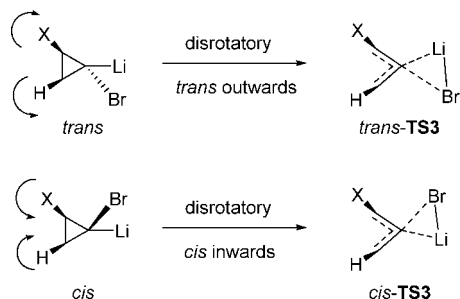

FIGURE 5. Torquoselectivity in the concerted ring opening of 1-bromo-1-lithiocyclopropanes.

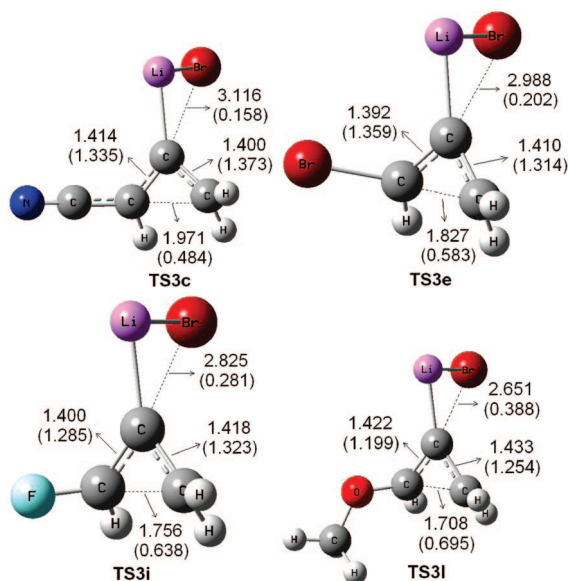

FIGURE 6. Optimized structures of **TS3c**, **TS3e**, **TS3i**, and **TS3l** with selected bond distances (Å) and bond orders (in parenthesis) at the B3LYP/6-31G(d) level.

isomerization of a carbenoid to an allene may occur readily without the intermediacy of a free carbene (Scheme 2). The transition structures **TS3** (**12** → **15**) for the substituted carbenoids were determined successfully (Figure 6), and the activation energy barriers for the isomerization of **12** to **15**, given in Table 2, were also calculated. The results imply that electron-withdrawing substituents, especially $-\text{CF}_3$ and $-\text{CN}$, increase the activation barriers. The same effect is responsible for the loss of the bromide ion in the stepwise process and therefore, similar activation energies are calculated for both processes (concerted (**TS3**) and stepwise (**TS1**)) for all substituents investigated. On the other hand, electron-supplying groups (e.g., $-\text{OH}$ and $-\text{NH}_2$) to the carbenoid provoke the ring to open with a low energy barrier. Moreover, the natural atomic charges on the carbenoidic carbons C(1) of **12** change from -0.458 to -0.570 when the substituent (X) is $-\text{H}$ and $-\text{OH}$, respectively.

As shown in Table 2, the energy barriers calculated at the DFT and MP2 levels of theory considerably differ. In general, MP2/6-31+G(d,p) level predicted higher activation energies in the range of approximately 5–8 kcal/mol than DFT levels (B3LYP/6-31G(d) and B3LYP/6-311++G(d,p)). It is well-known from previous studies on carbenes that DFT methods give more reliable results than MP2 methods.⁵¹ On the other hand, two methods do predict very similar trends for the concerted and stepwise isomerizations of carbenoids studied.

DFT calculations at B3LYP/6-31G(d) level were also afforded for the *cis* derivatives of 2-substituted 1-bromo-1-lithiocyclo-

SCHEME 3. Ring Opening of Free Cyclopropylidene **14** to Allene **15**

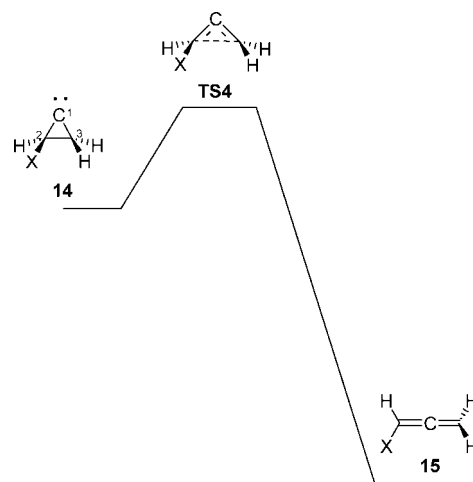

propanes, in which substituent (X) is *cis* to the leaving bromine. Concerning the torquoselectivity, the preference for “inward” or “outward” rotation of substituents in conrotatory or disrotatory electrocyclic ring opening reactions,^{52,53} the ring openings of *cis*- and *trans*-2-substituted 1-bromo-1-lithiocyclopropanes were analyzed by the help of GaussView 3.0 program (Figure 5). From the imaginary vibrational modes of *trans*-**TS3s**, the outward movement of the methylene and CH(X) groups upon the disrotatory concerted-ring opening of carbenoid is determined. On the contrary, the opposite disrotation (X group rotating inward) is favored for *cis*-diastereomer. IRC calculations^{39c} at B3LYP/6-31G(g) level also proved that the methylene and CH(X) group moves disrotatorily at the start of ring opening reaction of carbenoids to allenes (rotating outward for *trans* and inward for *cis* derivatives). The methylene group rotate faster than the CH(X) group until the transition structure (**TS3**) is reached. The more slowly rotating CH(X) group then reverses its sense of rotation after **TS3** is passed, so the overall motion then becomes conrotatory until the relative orientation of these groups is similar to that in the allene **15**.

For the parent carbenoid **12a** (X = $-\text{H}$), **TS3** could not be found. Instead of an elimination of LiBr, all performed calculations at B3LYP/6-31G(d), B3LYP/6-311++G(d,p), and MP2/6-31+G(d,p) levels lead to transition structure **TS1**. This means **12a** might intend to form the free carbene before rearranging to the allene. Moreover, the suitable transition structure of concerted ring-opening of the carbenoid **12b** (X = $-\text{SiH}_3$) could not be found. Instead, transition structure **TS2b** was located and characterized from the calculations at the levels of B3LYP/6-31G(d), B3LYP/6-311++G(d,p), and MP2/6-31+G(d,p). For the concerted ring-opening of **12a** and **12b**, IRC calculations linking their transition structures **TS3a** and **TS3b** to allene **15** could not be obtained.

(51) (a) Bettinger, H. F.; Schreiner, P. R.; Schleyer, P. v. R.; Schaefer, H. F. In *The Encyclopedia of Computational Chemistry*; Schleyer, P. v. R., Allinger, N. L., Clark, T., Gasteiger, J., Kollman, P. A., Schaefer, H. F., Schreiner, P. R., Eds.; John Wiley & Sons: Chichester, England, 1998; p 183–196. (b) Worthington, S. E.; Cramer, C. J. *J. Phys. Org. Chem.* **1997**, *10*, 755–767.

(52) (a) Kirmse, W.; Rondan, N. G.; Houk, K. N. *J. Am. Chem. Soc.* **1984**, *106*, 7989–7991. (b) Rondan, N. G.; Houk, K. N. *J. Am. Chem. Soc.* **1985**, *107*, 2099–2111.

(53) Recent studies on torquoselectivity: (a) Hasegawa, M.; Murakami, M. *J. Org. Chem.* **2007**, *72*, 3764–3769. (b) Zhao, Y. L.; Suh rada, C. P.; Jung, M. E.; Houk, K. N. *J. Am. Chem. Soc.* **2006**, *128*, 11106–11113. (c) Faza, O. N.; Lopez, C. S.; Alvarez, R.; de Lera, A. R. *J. Org. Chem.* **2004**, *69*, 9002–9010.

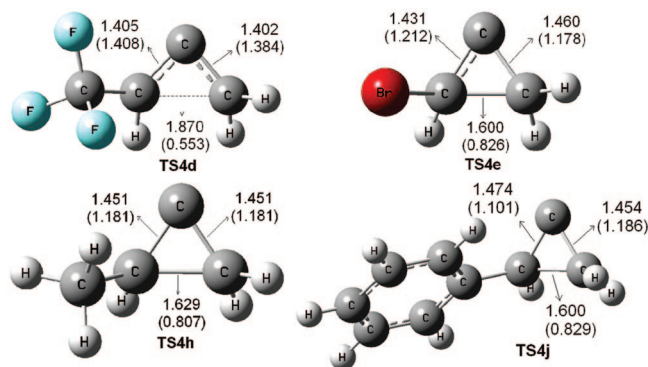

FIGURE 7. Optimized structures of **TS4c**, **TS3e**, **TS3i**, and **TS3l** with selected bond distances (Å) and bond orders (in parentheses) at the B3LYP/6-31G(d) level.

In transition states **TS3l**, **TS3i**, **TS3e**, and **TS3c**, the C(2)–C(3) bond distances increase to 1.708, 1.756, 1.827, and 1.971 Å from their values of 1.508, 1.495, 1.495, and 1.519 Å in carbenoids **12l**, **12i**, **12e**, and **12c**, respectively. Hence, the C(2)–C(3) bonds of transition states **TS3l**, **TS3i**, **TS3e**, and **TS3c** have low bond order values of 0.695, 0.638, 0.583, and 0.484, respectively, which indicate a weakening of the covalent bonding interactions between the C(2) and C(3) atoms. On the contrary, the C(1)–C(3) and C(1)–C(2) bond orders for **TS3l**, **TS3i**, **TS3e**, and **TS3c**, are higher, 1.199–1.254, 1.285–1.323, 1.359–1.314, and 1.335–1.373, respectively, which indicates the formation of a π -bond between the interconnected atoms (Figure 6).

Rearrangement of Free Cyclopropylidene 14 to Allene 15. Alternatively, the ring opening to allene **15** may also occur starting from free carbene **14** (**TS4**, Scheme 3). This has been studied extensively due to the interesting mechanistic aspect of this rearrangement.^{22,31–33,48,49} In agreement with an earlier published work,^{22,31,32} we also found that the imaginary vibrational modes of **TS4s** corresponds to the disrotatory motion of methylene and CH(X) groups in the initial phase of the ring opening of cyclopropylidene to allene as the C(2)–C(1)–C(3) angle opens (Figure 7). IRC calculations also showed that the CH(X) group reverses its sense of rotation relative to the methylene group after **TS4** is passed. The overall motion then becomes conrotatory until the relative orientation of these groups is similar to allene. For all substituted cyclopropylidenes studied, the ring-opening barriers leading to allenes are below 5 kcal/mol and monosubstitution on the β -carbon of the cyclopropylidene ring decreases the isomerization energy barrier to allene except for X = –SiH₃ and –CF₃ groups (Table 3). This decrease is especially significant with electron-donating substituents exhibiting a mesomeric effect (+M).

In some cases (X = –F, –OH, –OMe), the cyclopropylidene structure **14** cannot be found as a minimum. Instead, all attempts to locate these structures lead directly to allenes **15**. Accordingly, no **TS4** structures can be found. For these kinds of substituents, obviously the stepwise process does not play a role in the Doering–Moore–Skattebøl rearrangement.

In **TS4d**, **TS4e**, **TS4h**, and **TS4j**, the C(2)–C(3) distances are lengthened from 1.485, 1.477, 1.489, and 1.497 Å to 1.870,

TABLE 3. Calculated Energy Barriers for the Rearrangement of Free Cyclopropylidenes **14** at the B3LYP/6-31G(d), B3LYP/6-311++G(d,p) (in Parentheses) and MP2/6-31+G(d,p) (Underlined) Levels of Theory

	X	TS4 ^a TS(14 → 15)
a	–H	6.1/(4.7)/4.1
b	–SiH ₃	7.1/(6.4)/6.5
c	–CN	4.5
d	–CF ₃	7.0
e	–Br	1.4
f	–Cl	0.5/(0.1)/0.3
g	–CH ₂ OH	2.4
h	–CH ₃	2.2/(1.6)/1.6
i	–F	–/–/–
j	–Ph	0.9/(0.7)
k	–OH	–/–/–
l	–OCH ₃	–/–/–
m	–NH ₂	– ^b /(0.1)/– ^b

^a Energies in kcal/mol relative to **14a–m**, respectively. ^b For the NH₂ substituent, a structure corresponding to a bicyclic ylide is found instead of the cyclopropylidene structure. The activation energy barrier for the ring opening to the allene is calculated to be 4.5 and 9.8 kcal/mol at B3LYP/6-31G(d) and MP2/6-31+G(d,p) levels, respectively.

1.600, 1.629, and 1.600 Å, respectively, whereas the C(1)–C(2) and C(1)–C(3) distances are shortened from 1.405–1.402, 1.431–1.460, 1.451–1.451, and 1.474–1.454 Å, respectively, indicating that C(2)–C(3) σ -bond breaking and C(1)–C(2) and C(1)–C(3) π -bond formations happen in a concerted manner. This conclusion is also supported by the bond order values given in Figure 7.

Conclusions

The ring-opening reaction of monosubstituted (1-bromocyclopropyl)lithium to allene can occur either in a concerted fashion or through a stepwise process. In both cases, the efficiency of the process depends on the easiness of the splitting off of the bromide anion. This means electron-withdrawing substituents impede the reaction whereas electron-donating groups (+M) lower the barrier to allene formation. A similar effect is found for the reactivity of free carbene **14**: the cyclopropylidene structure cannot even be found as an energy minimum in the case of **14i**, **14k**, and **14l** (X = –F, –OH, –OMe, respectively).

Acknowledgment. A.A. is indebted to the Scientific and Technical Research Council of Turkey (Grant Nos. TUBITAK-TBAG-104T371 and TUBITAK-BIDEB-2219) for generous financial support. Some of the higher level calculations were performed on the Schrödinger III cluster at the University of Vienna. We are also grateful to the reviewers for their helpful suggestions.

Supporting Information Available: Tables listing energies, Cartesian coordinates, zero-point energies, and imaginary vibrational frequencies of transition states for all the calculated species. This material is available free of charge via the Internet at <http://pubs.acs.org>.

JO8011144